

Owner's Manual with Installation Instructions

Banks Ram-Air® Intake System

**2001-2008 Chevrolet/GMC 8.1L
Workhorse Class-A Motorhome**

THIS MANUAL IS FOR USE WITH SYSTEMS 49194 AND 49195

Gale Banks Engineering
546 Duggan Avenue • Azusa, CA 91702
(626) 969-9600 • Fax (626) 334-1743

Product Information & Sales: (800) 438-7693

bankspower.com

General Installation Practices

Dear Customer,

If you have any questions concerning the installation of your Banks Ram-Air System, please call our Technical Service Hotline at (888) 839-2700 between 7:00 am and 5:00 pm (PT). If you have any questions relating to shipping or billing, please contact our Customer Service Department at (888) 839-5600.

Thank you.

1. For ease of installation of your Banks power system, familiarize yourself with the procedure by reading the entire manual before starting work. This manual contains 24 pages of copy, illustrations and parts listing. If any pages are missing from this manual please call Gale Banks Engineering immediately for a replacement.

2. The exploded view of the Ram-Air assembly (pages 4-5) provides only general guidance. Refer to each step and section diagram in this manual for proper instruction.

3. Throughout this manual, the left side of the vehicle refers to the driver's side, and the right-side to the passenger's side.

4. Banks Ram-Air systems are designed to fit Chevy 8.1L Workhorse Class-A motorhome chassis. Due to differences in coach layouts, it may be necessary to relocate or modify some coach or Banks system components to accommodate installation of the Ram-Air system.

5. Disconnect the ground cable from the battery before beginning work. If there are two batteries, disconnect both.

6. Route and tie wires and hoses a minimum of 6 inches away from exhaust heat, moving parts and sharp edges. Clearance of 8 inches or more is recommended where possible.

7. During installation, keep the work area clean. If foreign debris is transferred to any Banks system component, clean it thoroughly before installing.

8. When raising the vehicle, support it on properly weight-rated safety stands, ramps or a commercial hoist. Follow the manufacturer's safety precautions. Take care to balance the motorhome to prevent it from slipping or falling. When using ramps, be sure the front wheels are centered squarely on the topsides; put the transmission in park; set the parking brake; and place blocks behind the rear wheels.

Caution! Do not use floor jacks to support the vehicle while working under it. Do not raise the vehicle onto concrete blocks, masonry or any other item not intended specifically for this use.

NOTE! To facilitate installation of the Banks Ram-Air intake tube, removal of the hood and engine access panel may be necessary.

Notification

The Banks Ram-Air Filter comes pre-oiled and no oiling is necessary for initial installation. Service the filter as specified in the "Ram-Air Filter Cleaning Instructions" Section of this manual.

Tools Required:

- 3/8" drive ratchets with metric sockets
- Standard and Phillips head screwdrivers
- Standard and needle-nose pliers
- Utility knife, keyhole saw or similar
- Clean shop towels or rags
- Drill motor
- 3/16" drill bit
- Pry bar or door panel pin remover
- 5/16" nut driver

Table of Contents

General Installation Practices . . .	2
Tools Required:	3
Section 1	4
General Assembly	
Section 2	6
Ram-Air Installation	
Section 3	20
Ram-Air Filter Cleaning Instructions	

Section 1

GENERAL ASSEMBLY

Figure 1

Bill of Materials

ITEM#	DESCRIPTION	QTY
1	THROTTLE BODY	--
2	HOSE CLAMP (4")	4
3	INTAKE ELBOW	1
4	BARBED PLASTIC CLIP	1
5	RAM AIR INTAKE TUBE	1
6	MAF TO INTAKE TUBE HOSE	1
7	#10-32 SLOTTED SCREW	3
8	MASS AIR FLOW (MAF) SENSOR	--
9	O-RING	1
10	RAM AIR FILTER COVER	1
11	RAM AIR FILTER ELEMENT	1
12	#10-32 HEX NUT, NYLOCK	9
13	#10 FLAT WASHER	18
14	AIR BOX	--
15	#10-32 X 3/4" HEX SCREW	9
16	AIR BOX INLET ADAPTER	1
17	HOSE CLAMP (5")	2
18	AIR BOX INLET HOSE (5")	1
19	SNORKEL OUTLET ADAPTER	1
20	INTAKE SNORKEL	--
--	AIR FILTER SERVICE KIT	1
--	OWNERS MANUAL	1

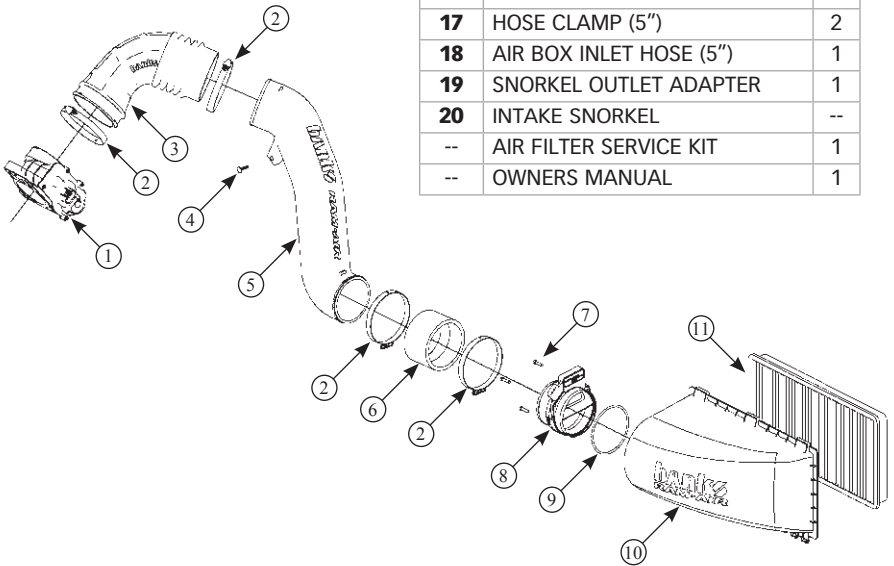

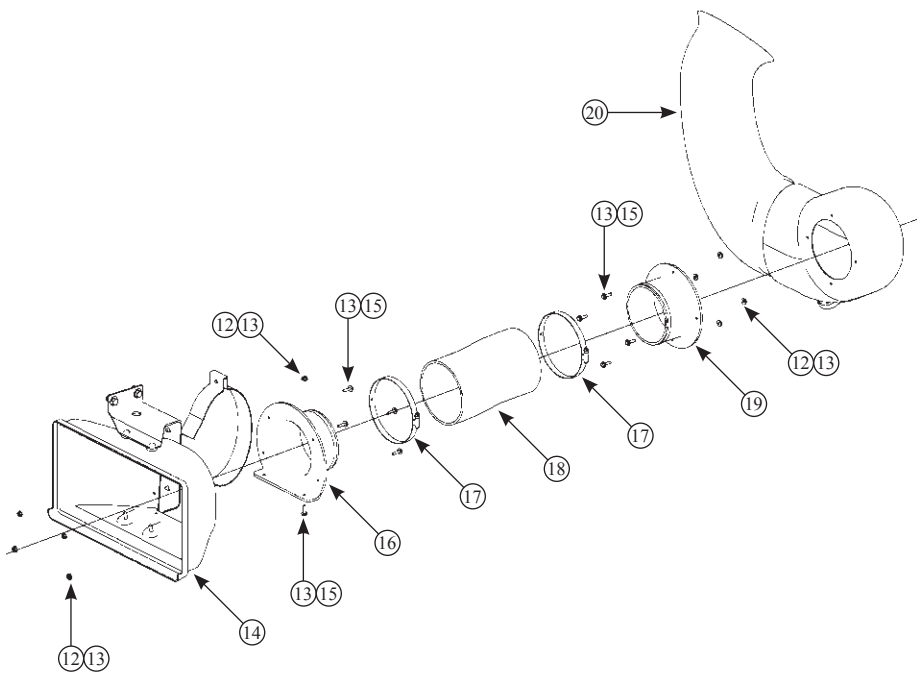

Section 2

RAM-AIR INSTALLATION

1. Use the Bill of Materials chart and the General Assembly drawing to reference component nomenclature and location.
2. From under the right wheel well, using a $\frac{5}{16}$ " nut driver, loosen both hose clamps located forward of air box (Item 14), closest to the air intake snorkel. Leave the rubber hose attached to the air box. See **Figure 2**.
3. Now go to the engine compartment for the removal of the stock intake snorkel (Item 20). Loosen and remove the bolt securing the stock air intake snorkel. Pull back the strap and remove the stock intake snorkel from engine compartment. Retain the bolt; it will be used for reassembly. See **Figure 3**.
4. From under the right wheel well, unplug the connector for the Mass Air Flow (MAF) sensor (Item 8) and place connector terminal out of the way.

The MAF sensor is attached to the stock air filter cover. While still under the right wheel well, loosen the hose clamp attaching the stock air intake tube to the MAF sensor. Leave the air inlet tube and MAF sensor attached to the stock air box cover at this time. See **Figure 4**.

5. Remove the plastic panel clip that fastens the stock air inlet tube to the fan shroud. You will need to use a prying device to remove the clip. Discard this clip after removal. Separate the air inlet tube from the MAF sensor. See **Figure 5**.

Note: The hose clamp at the throttle body (Item 1) can be accessed from under the right wheel well area or the front engine compartment.

6. Loosen the hose clamp at the throttle body and separate the rubber elbow from the throttle body. Remove the rubber elbow and air intake tube from the vehicle. See **Figure 6**.

Figure 2



Figure 3

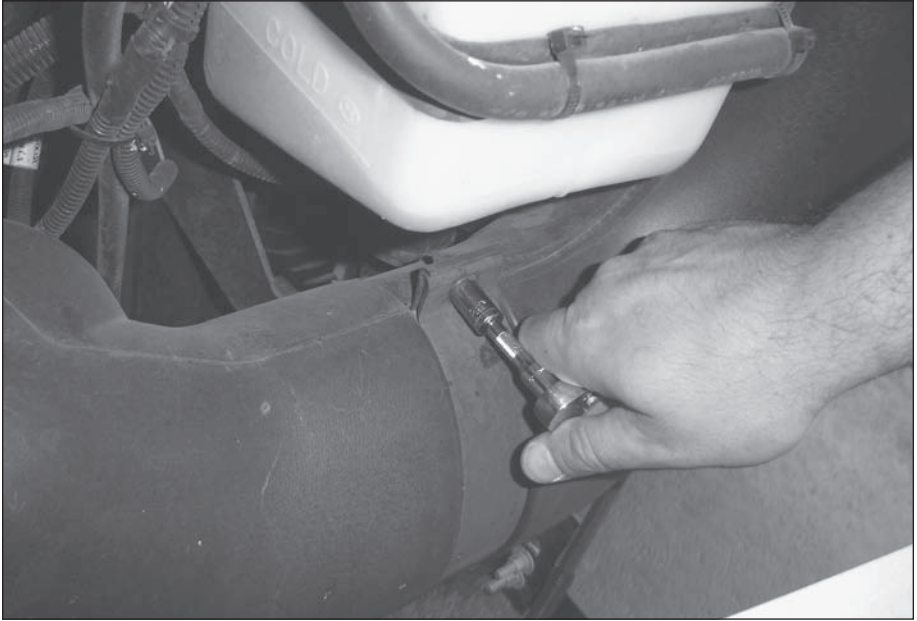

Figure 4

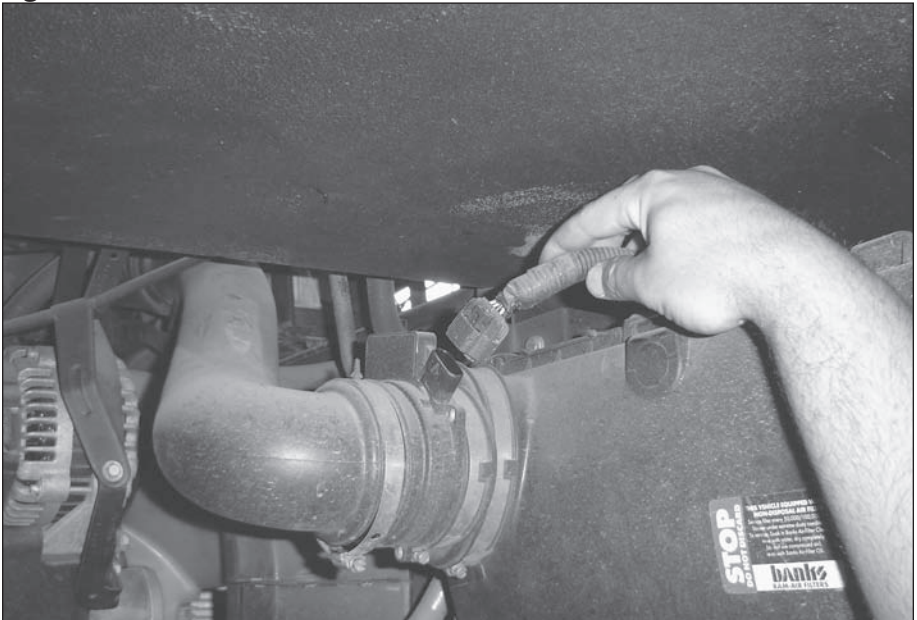

Figure 5

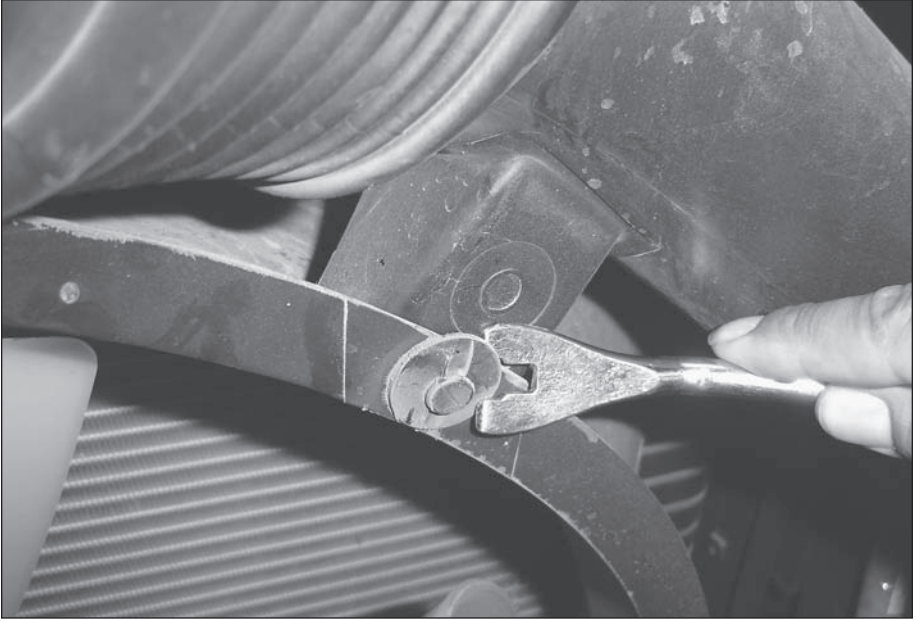
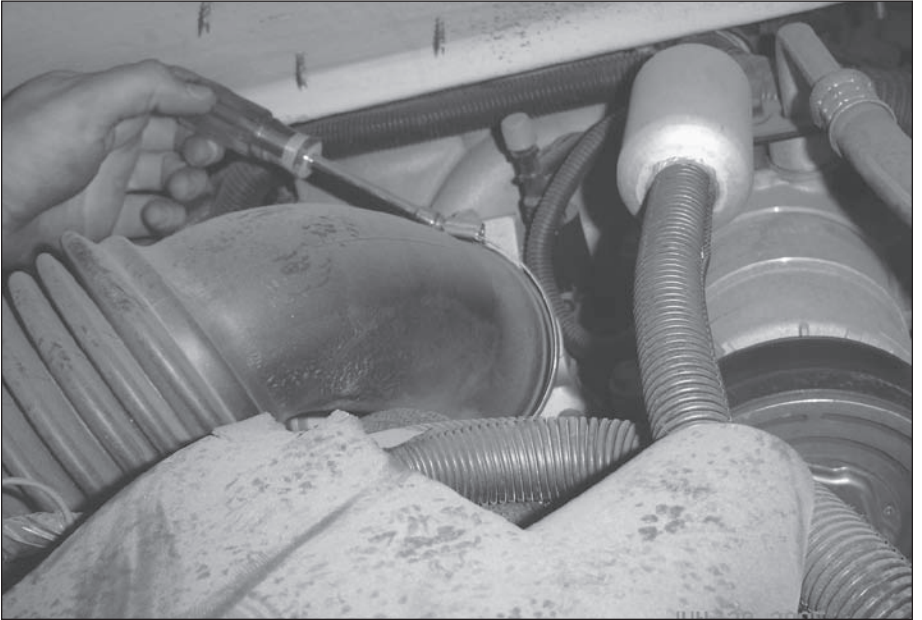

Figure 6



7. Loosen the hose clamp securing the MAF sensor to the air filter cover. Remove the MAF sensor from the hose attached to the air filter cover and place in a clean and safe area. See **Figure 7**. Unclip air filter cover (3 clips) and remove it from the air box. Remove the air filter. If you have a stock air filter, it may be discarded. If you already have a Banks Ram Air filter element (Item 11), service it, if required, and set aside for reinstallation later.

8. The air box (Item 14) and bracket must be removed for modification. There are 4 bolts securing the air box bracket to the frame. These bolts are accessed from under the right wheel well. Loosen and remove the bolts, then remove air box and bracket from the vehicle. Depending on your specific coach model, it may be necessary to loosen and remove two bolts that fasten the bracket for the air inlet snorkel to the frame. The bolts

are located behind the strap that held the air inlet snorkel. Retain the bolts; they will be used later for reassembly. See **Figure 8**.

9. Locate the plastic retaining pin on the air box and remove with a prying device. See **Figure 9**. Grab hold of the rubber hose attached to air box inlet adapter and pry the adapter off the air box. *Note: the air box inlet adapter is a snap fit removable piece. Remove it carefully. The air box inlet adapter and attached hose will not be used and can be discarded.*

10. Place the air box on a flat, sturdy surface, with the filter opening face down. Locate the air box inlet adapter (Item 16). Fit the air box inlet adapter in place over the inlet opening.

Note: the air box bracket will slightly interfere but will not prevent the proper alignment of the air inlet adapter with the opening on the air box. The air box inlet adapter will be

Figure 7



Figure 8

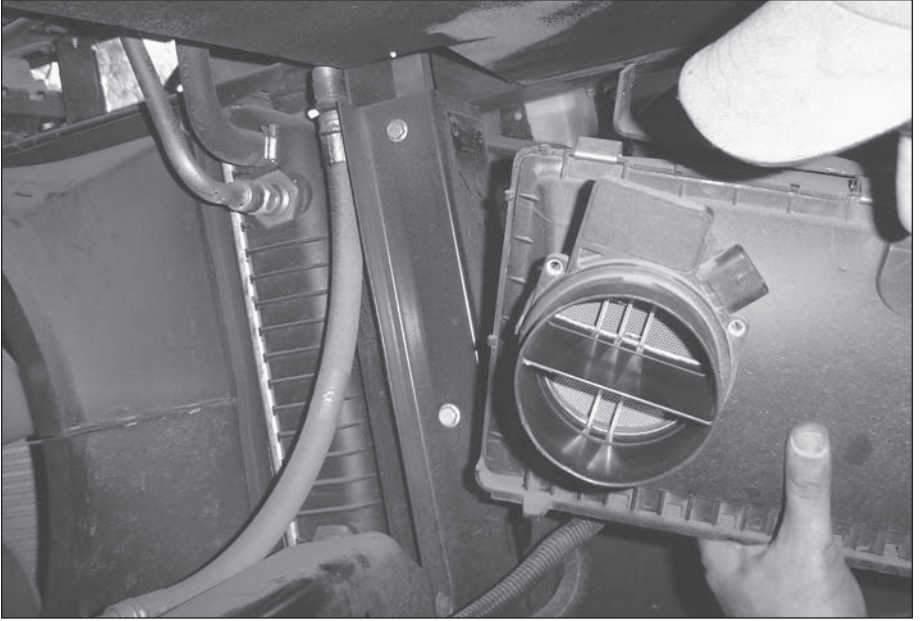
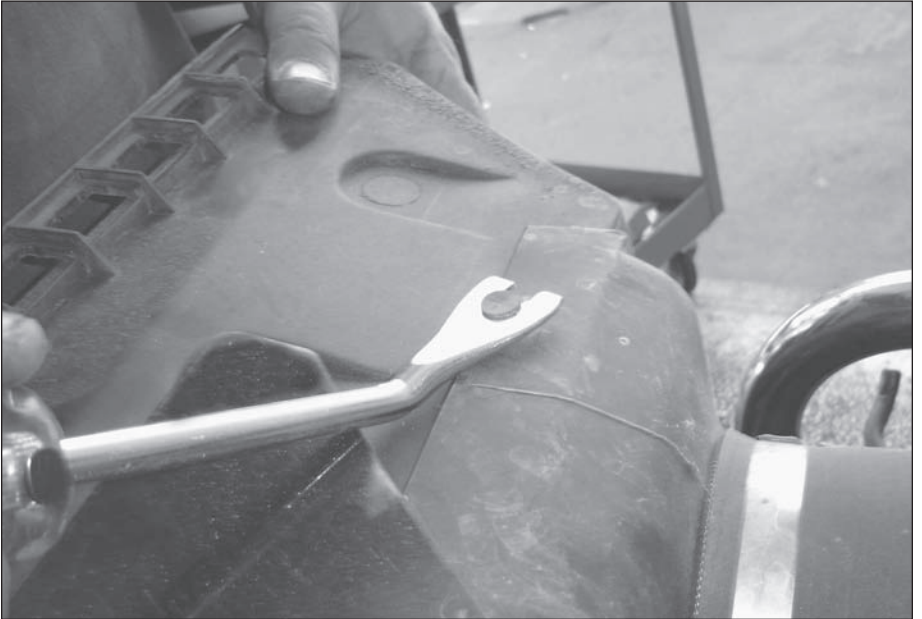

Figure 9



slightly off center when viewed from the inside of the air box. This is the intended alignment. See **Figure 11**.

11. Line up air box inlet adapter over air box so that front and side edges of both parts are even when viewed with the air filter opening face down. Using the existing holes in the air box inlet adapter as a template, drill five (5) $\frac{3}{16}$ " holes into the air box. Fasten both parts with supplied bolts (5), lock nuts (5), and flat washers (10) (Items 12,13,15). See **Figure 10**.

Note: there is a sixth hole in the Banks air box inlet adapter that will not be transferred to the air box because it is hidden behind the mounting bracket. Access to this hole is not necessary for proper fitment and function of the parts.

12. From under the right wheel well area, reinstall the air box and bracket (Item 14) to vehicle frame. Line up

Figure 10

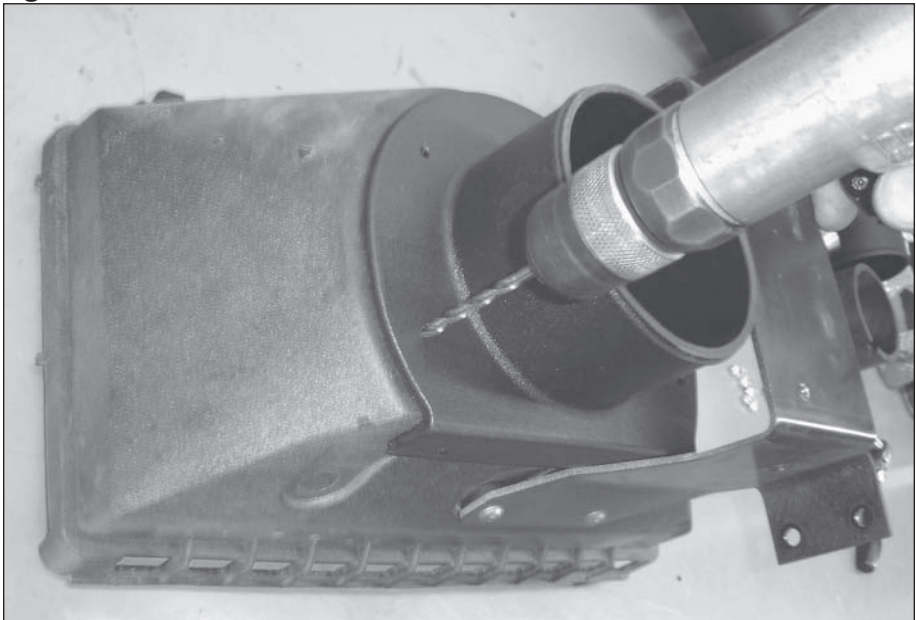

the bracket holes and fasten to frame using the original bolts previously removed in **step 8**.

13. Retrieve the MAF sensor previously removed in **step 7** and carefully clean all mating surfaces. On the MAF sensor inlet (metal side), install the supplied o-ring (Item 9) as shown in **Figure 12**.

14. Install the MAF sensor with supplied o-ring onto the Banks Ram Air filter cover (Item 10). *Note: The MAF sensor will align to the Banks Ram Air cover in only one position. To fasten the MAF sensor and Banks Ram Air filter cover use the supplied slotted screws (Item 7). After assembling, place Banks Ram Air filter cover and MAF sensor aside. These will be installed in a later step.*

15. Locate the Banks Ram-Air intake tube (Item 5) and intake elbow (Item 3). Loosely assemble the hose

Figure 11

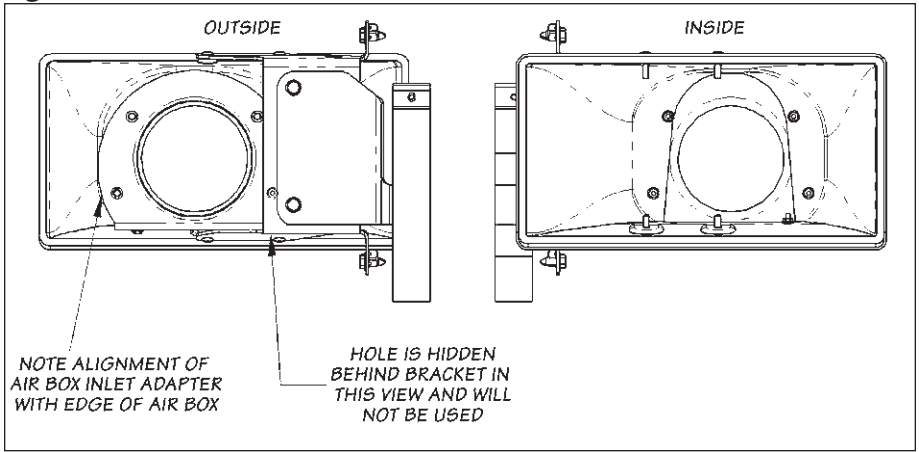

clamp (Item 2) connecting the Banks Ram-Air intake tube and intake elbow. Loosely assemble another hose clamp on the outlet side of the intake elbow. See **Figure 13**.

16. From under the right wheel well install the intake elbow and Banks Ram-Air intake tube. Install the parts loosely and only snug the hose clamps once correct alignment is attained.

Figure 12



Figure 13

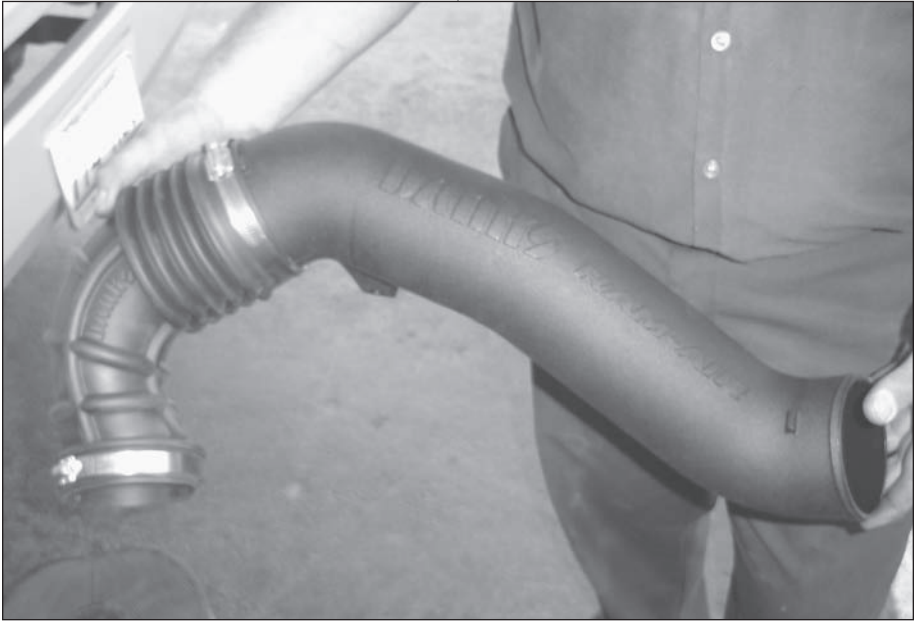

Figure 14

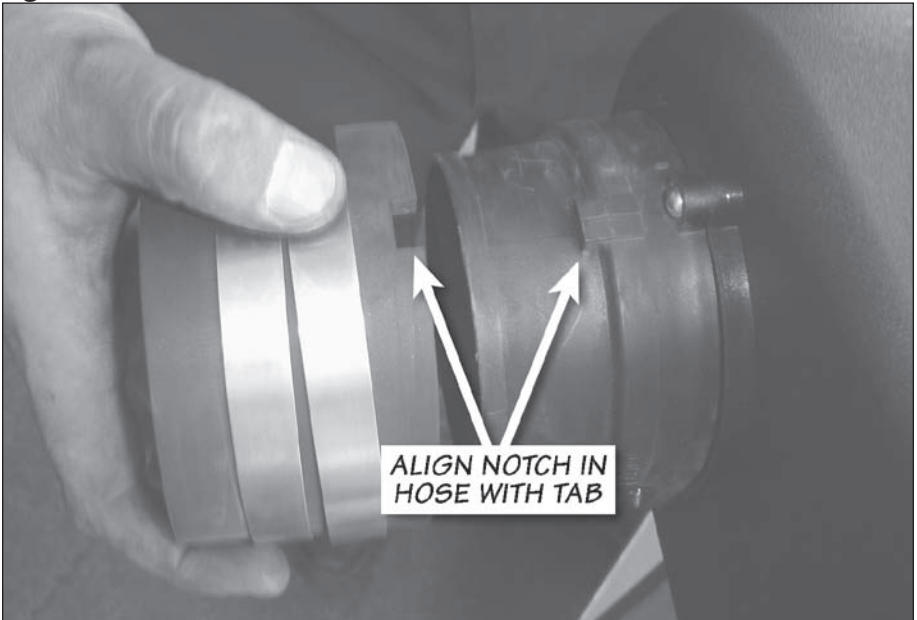

Figure 15



Figure 16



17. Locate the supplied MAF to intake tube hose (Item 6) with the square notch cutout and the MAF sensor attached to Banks Ram-Air filter cover. Slide the MAF to intake tube hose onto the MAF sensor. Make sure the square notch cutout and the tab on the MAF sensor line up and fit snug. Tighten the hose clamp (Item 2) to secure the MAF to intake tube hose to the MAF sensor but leave the hose clamp on the other end of the hose adapter loose. See **Figure 14**.

18. Under the right wheel well, install the Banks Ram-Air filter into the air box. Install the Banks Ram-Air filter cover, with attached components, to the Banks Ram-Air intake tube (Item 5). Slide the two components together until the hose adapter is against the stops on the Banks Ram-Air inlet tube. Once correct alignment is achieved, install Banks Ram-Air filter cover into place on the air box. Fasten the three

clips to secure it. See **Figure 15**.

19. Locate the MAF sensor connector terminal previously disconnected in step 4. Plug in the connector to the MAF sensor.

20. Go over entire air intake system and ensure all hose clamps and hose adapters are correctly aligned. Fasten the Banks Ram-Air intake tube by installing the barbed plastic clip (Item 4) through the existing hole in fan shroud and intake tube mounting tab. See **Figure 16**. After barbed plastic clip is installed, tighten all hose clamps installed in previous steps.

21. Place the intake snorkel (Item 20), on a sturdy flat surface, on the its front (snorkel down and outlet up). Locate the supplied snorkel outlet adapter (Item 19) and slip over the stock snorkel outlet. See **Figure 17**.

Figure 17



22. Visually center the Banks snorkel outlet adapter over the stock snorkel outlet. Using the Banks snorkel outlet adapter as a template, drill a $\frac{3}{16}$ " hole into the snorkel through one of the existing holes in the adapter. See **Figure 18**.

23. Temporarily insert a supplied screw with a washer through the Banks outlet adapter and intake snorkel. Install another washer and nut on the screw from inside the snorkel, with the nut finger tight. Ensure both pieces are still visually centered and aligned with the mark made earlier, then drill the remaining three holes using the Banks snorkel outlet adapter as the template. See **Figure 19**.

24. Remove Banks outlet adapter and set aside.

25. With a felt marker or scribe, and using the stock outlet adapter as a center point, draw a circle $\frac{3}{16}$ " offset from the stock outlet on the intake snorkel. Using a utility knife, keyhole saw, or similar, cut along the marked circle to remove the stock outlet and enlarge the opening. See **Figure 20**.

Note: The $\frac{3}{16}$ " offset is only a reference dimension and is not critical. Make sure that the new hole is at least

*5" in diameter and does not break into the Banks adapter mounting holes drilled earlier. See **Figure 21**.*

26. After the hole has been cut and the stock outlet fitting is removed, debur all cut areas. Line up the screw holes in the Banks snorkel outlet adapter with the drilled holes in the snorkel. Fasten them together using the supplied screws (4), lock nuts (4), and washers (8) (item 12,13,15). Each screw should have a flat washer on both sides of the joint.

27. Locate the air box inlet hose (Item 18). Loosely fit two hose clamps (Item 17) onto the hose and install the hose onto the modified inlet of the air box. Tighten the clamp securing the hose to the air box.

28. If previously removed, install the intake snorkel bracket and bolts onto the frame and tighten.

29. Install the intake snorkel outlet into the hose inlet and then slip on the snorkel strap and fasten to the bracket. Tighten the clamp securing the hose to the snorkel outlet. Tighten the snorkel strap with the previously removed bolt.

-END, SECTION 2-

Figure 18

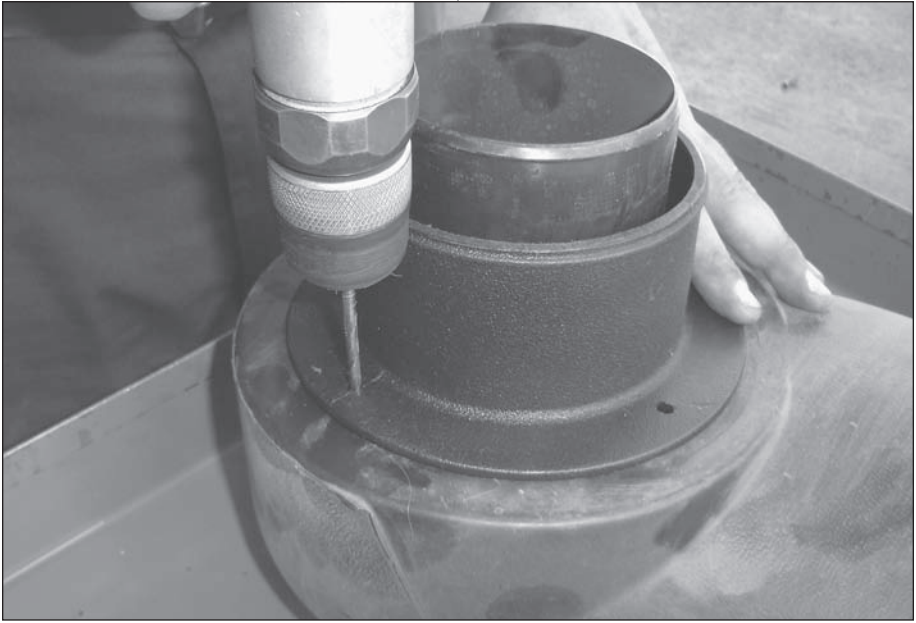

Figure 19

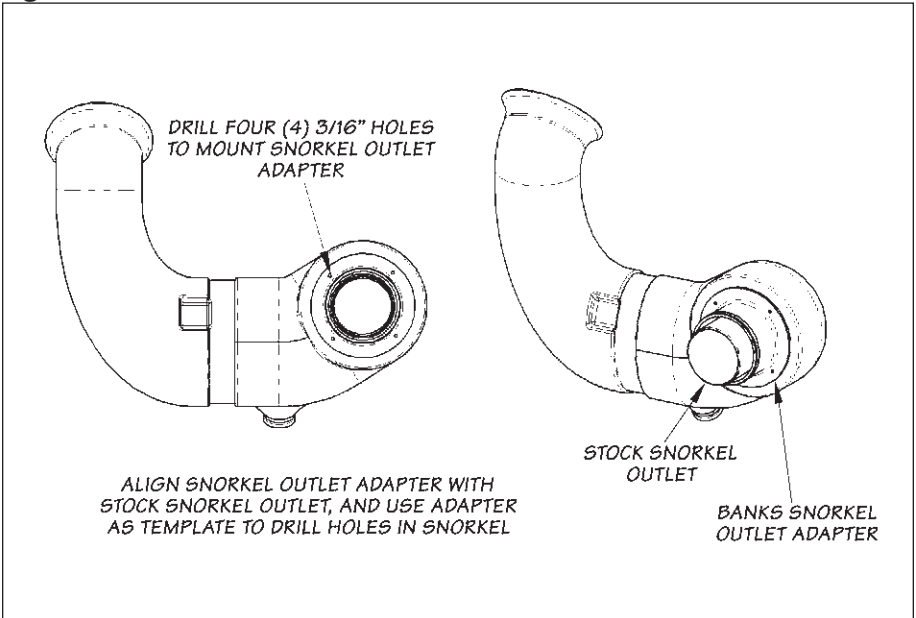
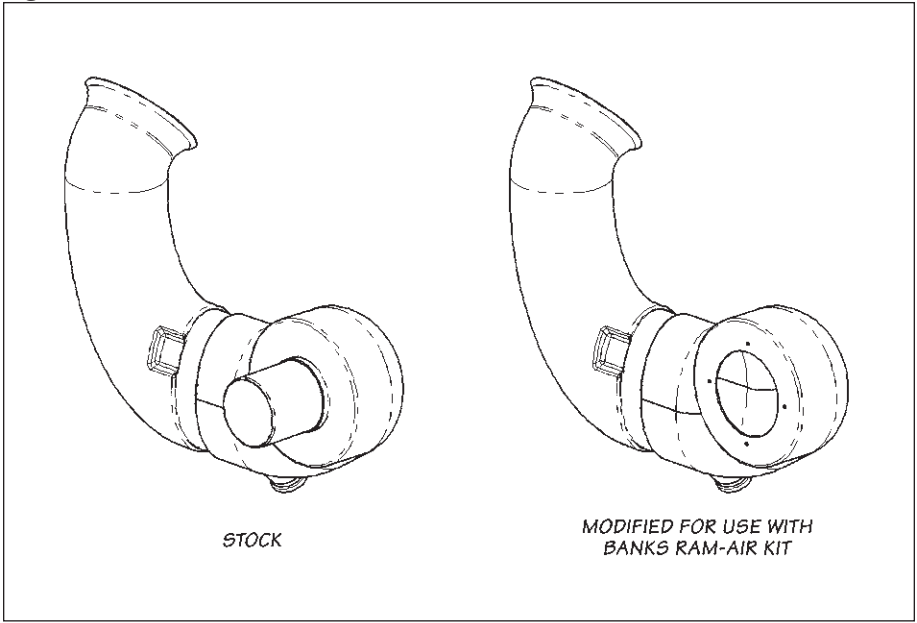

Figure 20



Figure 21



Section 3

RAM-AIR FILTER CLEANING INSTRUCTIONS

Notification

The Banks Ram-Air Filter comes pre-oiled and no oiling is necessary for initial installation. Use Banks Ram-Air Filter cleaning system (part# 90094), available from Gale Banks Engineering to service the Ram-Air Filter. Follow the instructions included with the cleaning system to clean and re-oil your Banks Ram-Air Filter.

1. PRE-CLEANING

Tap the element to dislodge any large embedded dirt, then gently brush with a soft bristle brush. *NOTE: If complete cleaning is not practical at this time, recoil the element and reinstall in your vehicle.*

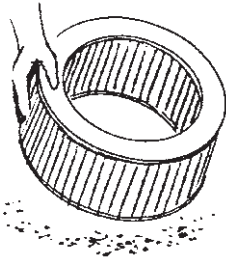

2. SPRAY-ON CLEANING

Spray Banks air-filter cleaner liberally onto the entire element and let soak for 10 minutes.

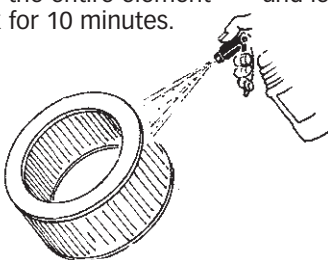

PAN CLEANING

Large air-filter elements can be rolled or soaked in a shallow pan of Banks air-filter cleaner. Remove immediately and let soak for approximately 10 minutes.

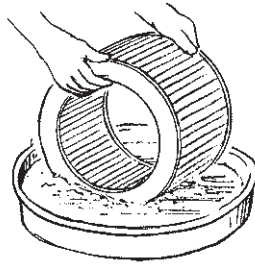

3. CLEANING HINTS

Use only Banks air-filter cleaner. No gasoline cleaning, No steam cleaning, No caustic cleaning solutions, No strong detergents, No high-pressure car wash, No parts cleaning solvents. Any of these No's can cause harm to the cotton filter media plus SHRINK and HARDEN the rubber end caps.

4. RINSE OFF

Rinse off the element with low-pressure water. Tap water is okay. Always flush from the clean side to dirty side. This removes the dirt and does not drive it into the filter.

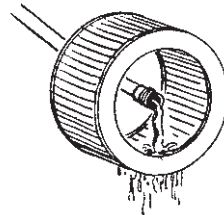

5. DRYING HINTS

Always dry naturally. After rinsing, shake off all excess water and let the element dry naturally. **DO NOT USE COMPRESSED AIR – DO NOT USE OPEN FLAME – DO NOT USE HEAT DRYERS!**

EXCESS HEAT WILL SHRINK THE COTTON FILTER MEDIA. COMPRESSED AIR WILL BLOW HOLES IN THE ELEMENT.

6. AEROSOL OILING

After cleaning air filter always reoil before using. Spray Banks Ram-Air filter oil down into each pleat with one pass per pleat. Wait 10 minutes and re-oil any white spots still showing.

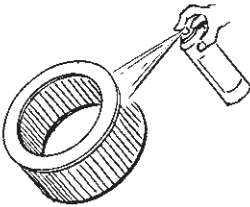

7. OILING HINTS

Never use a Banks Ram-Air filter without oil (the filter will not stop the dirt without the oil). Use only Banks Ram-Air filter oil. Banks air-filter oil is a compound of mineral and animal oil blended with special polymers to form a very efficient tack barrier. Red dye is added to show just where you have applied the oil. Eventually the red color will fade but the oil will remain and filter the air. **NEVER USE Automatic Transmission Fluid. NEVER USE Motor Oil. NEVER USE Diesel Fuel. NEVER USE WD40, LPS, or other light-weight oils.**

8. REINSTALL

Reinstall your Banks Ram-Air filter element with proper care. Make sure the element seats properly in the filter case. Install the cover making sure it's in the right position. Tighten all the nuts, bolts, screws or clips to factory specifications.

9. DO NOT DISCARD

Affix the "Do Not Discard" sticker to the filter case (included with every Banks replacement element). Make sure you put the sticker in a highly visible place to alert your mechanic not to discard.

10. PERFORMANCE HINTS

Service every 50-100,000 miles on street-driven applications. Service more often in offroad or heavy-dust conditions. If an air-filter restriction gauge is installed, then change the element when the air-filter restriction reaches 18"-H.O.

CAUTION! Extremely fine dust from agriculture or offroad use will pull the oil from the element. Frequent reoiling of the element's clean side might be required. Completely service when practicable. For extra protection use an air-filter sealing grease on rubber ends of the element. Service only with Banks air-filter cleaner and Banks air-filter oil.

-END, SECTION 3-

Notes

Notes

Gale Banks Engineering
546 Duggan Avenue • Azusa, CA 91702
(626) 969-9600 • Fax (626) 334-1743

Product Information & Sales: (800) 438-7693

bankspower.com